



广州华臻机械设备有限公司

GUANGZHOU SINO ACHIEVE MECHANICAL EQUIPMENT CO.,LTD.

-  广州市花都区赤坭镇培正路34号之六
NO.34 Peizheng Road ,Chini Town ,Huadu District ,Guangzhou ,China
-  www.gzsame.com www.samewaterjet.com
-  +400-843-2880(国内免费咨询电话)
-  +86-020-86718082(DOMESTIC国内)
-  +86-020-89680086(INTERNATIONAL国际)
-  510830  +86-020-86713493 (传真)  info@gzsame.com



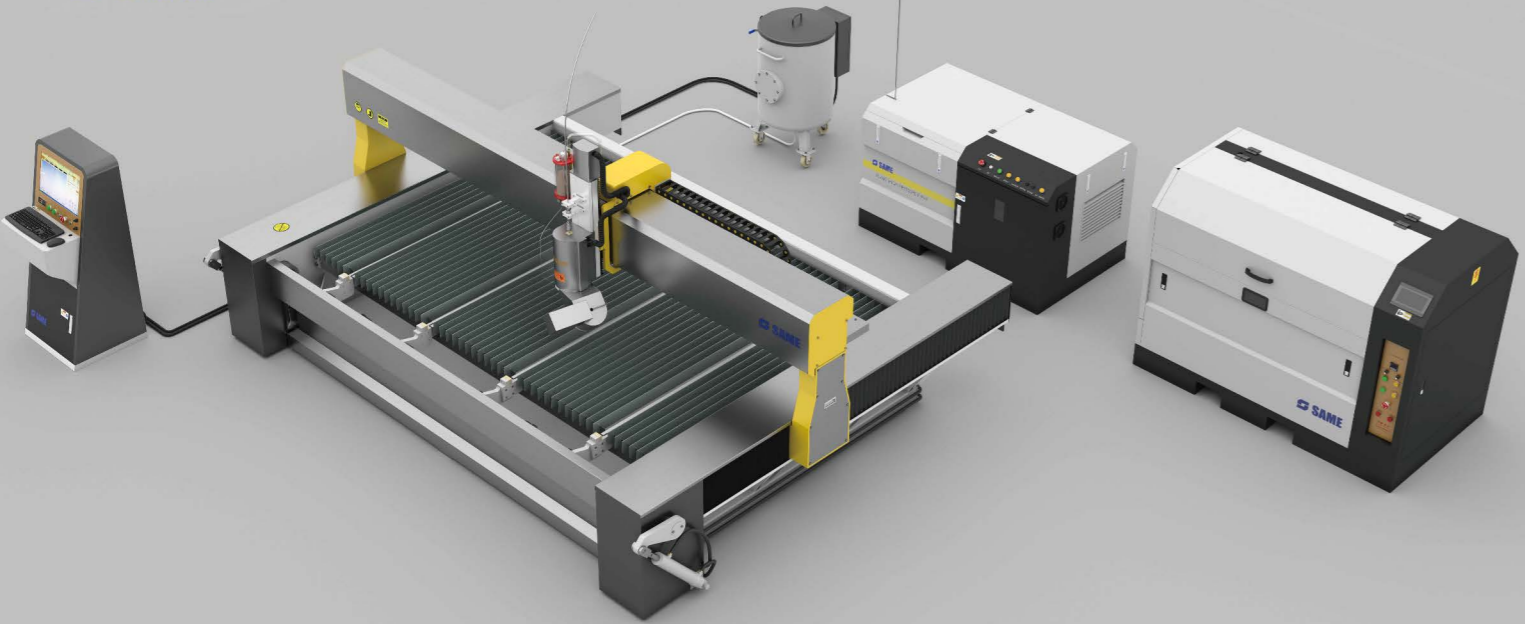

COMPANY PROFILE

公司简介

广州华臻成立于1997年,中国最早的水刀生产厂家之一,同年与中国机械装备集团合肥通用机械研究院合作,研制出中国第一台直驱式水刀,获得广东省科技进步奖,中央电视台以此为题材拍摄纪录片《神奇的水柱》在“星火科技”栏目中播出。多年来,华臻人专注于水射流技术,积极参与国家科研项目,拥有强大的研发、生产、销售和服务团队。产品遍布全国,并远销德国、日本等六十多个国家和地区。

Established in 1997, Guangzhou Sino Achieve Mechanical Equipment Co. Ltd.(SAME WATERJET) is one of the earliest enterprises that engaged in research and manufacture of ultrahigh pressure water jet technology. With over 22 years history,SAME has become member of Jet Equipment Standardization committee of State Bureau of Machine-Building Industry, Chinese Structural Glass and Industrial Glass Association, Guangdong Dimension Stone Industrial Association and Guangdong Glass Industrial Association. SAME is the first domestic enterprise to apply the three cylinder plunger direct drive pump to the ultrahigh pressure cutting field successfully in China.

科研能力:

- ★ 参与制定中国机械行业标准《机器人超高压水切割机JB/YT13245》
- ★ 参与制定中国首部水刀国家标准《超高压水切割机GB/T261362010》
- ★ 国家重点研发计划《超高压水切割深海破拆装备研制》课题承担单位
- ★ 国家863计划《复合及特种耐高温材料超高压水射流加工装备与工艺》课题承担单位
- ★ 核心技术团队由水射流行业资深专家组成,其中全国标准化技术委员会委员两名,副省级高层次人才两名,获得二十余项国家专利。

- ★ Participate in the formulation of China first national standard for water jet (ultra high pressure water jet cutting machine GBET26136-2010)
- ★ Participate in the formulation of China machinery industry standards(robot ultra high pressure water jet cutting machine (JB/YT13245)
- ★ Member of China 863 plan(ultra-high pressure water jet processing equipment technology for composite and high-temperature resistant materials)
- ★ Member of China research and development plan for<ultra-high pressure water cutting for deep sea breaking equipment research and developments
- ★ The core technical team is composed of senior experts in the water jet industry, including two members of the national standardization technical committee and one deputy high-level talent at the provincial level. More than 20 national patents have been obtained

资质荣誉:

- ★ 欧盟CE认证
- ★ 广州市著名商标
- ★ 广东省科技进步奖
- ★ 国家高新技术企业
- ★ 广东省高新技术产品
- ★ ISO9001国际质量体系认证
- ★ 广东省玻璃工业协会玻璃机械装备分会副会长

SCIENTIFIC RESEARCH ABILITY

- ★ European CE certification
- ★ Famous trademark of Guangzhou
- ★ Guangdong science and technology progress award
- ★ China high-tech enterprise
- ★ High-tech products of guangdong province
- ★ ISO9001 international quality system certification
- ★ Vice President of glass machinery equipment branch of Guangdong glass industry association

Enterprise Qualifications

企业资质



获得20余项国家专利!



Business Partners

合作伙伴



01

Water jet cutting machine for porcelain slabs cut

岩板深加工专用水刀套机 (50HE-4020L-5XAC)



4020 龙门式切割平台
4020 Gantry Cutting Type Platform

AC五轴切割刀头
AC5 Axis Cutting System

CNC 控制系统
CNC Control System

自动供砂系统
Automatic Abrasive Feeder

50HE 液压式超高压泵
50HE Hydraulic High Pressure Pump

02

Specialty Water jet cutting machine for glass deep processing

玻璃深加工专用水刀套机 (50HE-3020)



3020 悬臂式切割平台
3020 Cantilever Type Cutting Table

CNC 控制系统
CNC Control System

自动供砂系统
Automatic Abrasive Feeder

50HE 液压式超高压泵
50HE Hydraulic High Pressure Pump

03

Water jet cutting machine for stone/ceramic tiles cut

石材陶瓷拼花专用水刀套机 (50HE-3020L-5X0AB)



3020 龙门式切割平台
3020 Gantry Type Cutting Table

OAB五轴切割刀头
OAB5 AXIS CUTTING SYSTEM

CNC 控制系统
CNC Control System

自动供砂系统
Automatic Abrasive Feeder

50HE液压式超高压泵
50HE Hydraulic High Pressure Pump

04

Water jet cutting machine
for Mosaic cut

马赛克专用水刀套机（双刀头）(50HE-2516L-DZ)

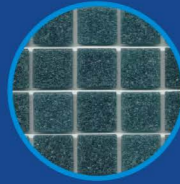

CNC 控制系统
CNC Control System

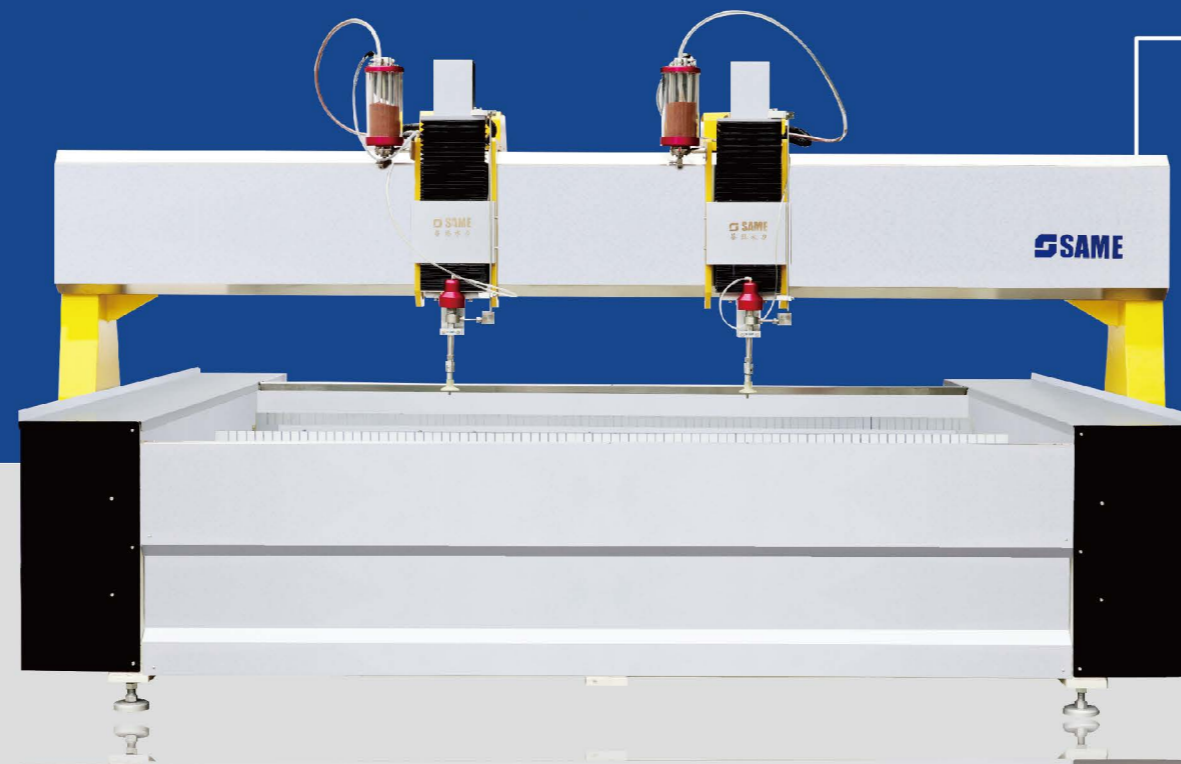

2516 龙门式切割平台
2516 Gantry Type Cutting Table



自动供砂系统
Automatic Abrasive Feeder

50HE 液压式超高压泵
50HE Hydraulic High Pressure Pump

50HE HYDRAULIC HIGH PRESSURE PUMP 50HE液压式超高压泵

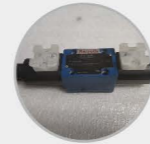

BOSCH REXROTH REVERSING VALVE
博世力士乐换向阀



STAINLESS STEEL WATER SUPPLY AND FILTRATION SYSTEM
不锈钢供水、过滤系统



REXROTH HYDRAULIC PUMP
博世力士乐变量柱塞泵



SIEMENS MOTOR
西门子电机



STAINLESS STEEL OIL TANK
不锈钢油箱



REXROTH HYDRAULIC PUMP
博世力士乐电液比例阀

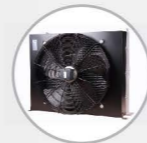

AIR-COOLING SYSTEM
风冷却系统

50HC HYDRAULIC HIGH PRESSURE PUMP 50HC液压式超高压泵



BOSCH REXROTH REVERSING VALVE
博世力士乐换向阀



STAINLESS STEEL WATER SUPPLY AND FILTRATION SYSTEM
不锈钢供水、过滤系统



REXROTH HYDRAULIC PUMP
博世力士乐变量柱塞泵



SIEMENS MOTOR
西门子电机



STAINLESS STEEL OIL TANK
不锈钢油箱



REXROTH HYDRAULIC PUMP
博世力士乐电液比例阀



WATER CHILLER SYSTEM
水冷却系统



BRAZED PLATE HEAT EXCHANGER
板式换热器

性能技术参数 / TECHNICAL PARAMETER

外形尺寸(长*宽*高) Dimension(L*W*H)	1800*1050*1300(mm)
重量 Weight	1200Kg
电机功率 Power rate	37KW/50HP
最高输出压力Max.pressure	420MPa/4200bar
持续工作压力Working pressure	300-350MPa
最大水流量Max. flow rate	3.7L/min
最大宝石喷嘴直径Max. Φ of orifice	0.35mm
工作电源Power supply	380V 50HZ
供水流量Water supply	≥ 15.1L/min
供水压力Water pressure	≥ 0.1MPa

特点描述 :

- ◆ 按照CE, ISO9001国际标准设计
- ◆ 采用德国力士乐液压系统
- ◆ 西门子贝得节能型电机
- ◆ 进口PLC系统及人机对话窗口
- ◆ 可设置两级压力,适应各种材料切割
- ◆ 内置风冷系统,无需外接冷却水源

ATTRIBUTE :

- ◆ Designed in accordance with CE and ISO9001 international standards
- ◆ Adopt German Bosch Rexroth hydraulic system
- ◆ Siemens(Beide) energy saving motor
- ◆ PLC system with touch screen
- ◆ Two - stage pressure setting, suitable for cutting various materials
- ◆ Built-in air cooling system, no need external cooling water

性能技术参数 / TECHNICAL PARAMETER

外形尺寸(长*宽*高) Dimension(L*W*H)	1800*1050*1300(mm)
重量 Weight	1200Kg
电机功率 Power rate	37KW/50HP
最高输出压力Max.pressure	420MPa/4200bar
持续工作压力Working pressure	300-350MPa
最大水流量Max. flow rate	3.7L/min
最大宝石喷嘴直径Max. Φ of orifice	0.35mm
工作电源Power supply	380V 50HZ
供水流量Water supply	≥ 15.1L/min
供水压力Water pressure	≥ 0.1MPa

特点描述 :

- ◆ 按照CE, ISO9001国际标准设计
- ◆ 采用德国力士乐液压系统
- ◆ 西门子贝得节能型电机
- ◆ 进口PLC系统及人机对话窗口
- ◆ 可设置两级压力,适应各种材料切割
- ◆ 水冷系统

ATTRIBUTE :

- ◆ Designed in accordance with CE and ISO9001 international standards
- ◆ Adopt German Bosch Rexroth hydraulic system
- ◆ Siemens(Beide) energy saving motor
- ◆ PLC system with touch screen
- ◆ Two - stage pressure setting, suitable for cutting various materials.
- ◆ Equipped with external water chiller

HJ400 DIRECT-DRIVE WATERJET PUMP HJ400直驱式超高压泵

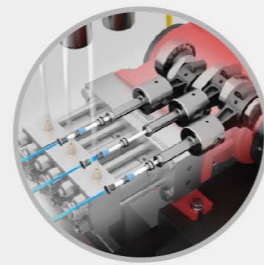

性能技术参数 / TECHNICAL PARAMETER

外形尺寸(长*宽*高)Dimension(L*W*H)	1600*980*950(mm)
重量Weight	600Kg
电机功率Power rate	18.5KW/25HP
最高输出压力Max.pressure	400MPa/4000bar
持续工作压力Working pressure	200-300MPa
最大水流量Max. flow rate	4L/min
最大宝石喷嘴直径Max. Φ of orifice	0.35mm
工作电源Power supply	380V 50HZ
供水流量Water supply	≥ 15.1 L/min
供水压力Water pressure	≥ 0.1 MPa

特点描述：

- ◆ 节能专利技术,每小时实际耗电5-10度
- ◆ 与液压增压器式高压泵比较,同等压力,切割效率提升20%
- ◆ 无液压传动环节,维修简单
- ◆ 低能耗,大流量,高压力

ATTRIBUTE :

- ◆ Patented energy saving technology, consumes 5kw-10kw of electricity per hour
- ◆ Compare with the hydraulic type high pressure pump, with same pressure, cutting efficiency increase by 20%
- ◆ No hydraulic transmission link, easy for maintenance
- ◆ Low energy consumption, high flow and high pressure

CANTILEVER TYPE CUTTING TABLE WT系列悬臂式切割平台

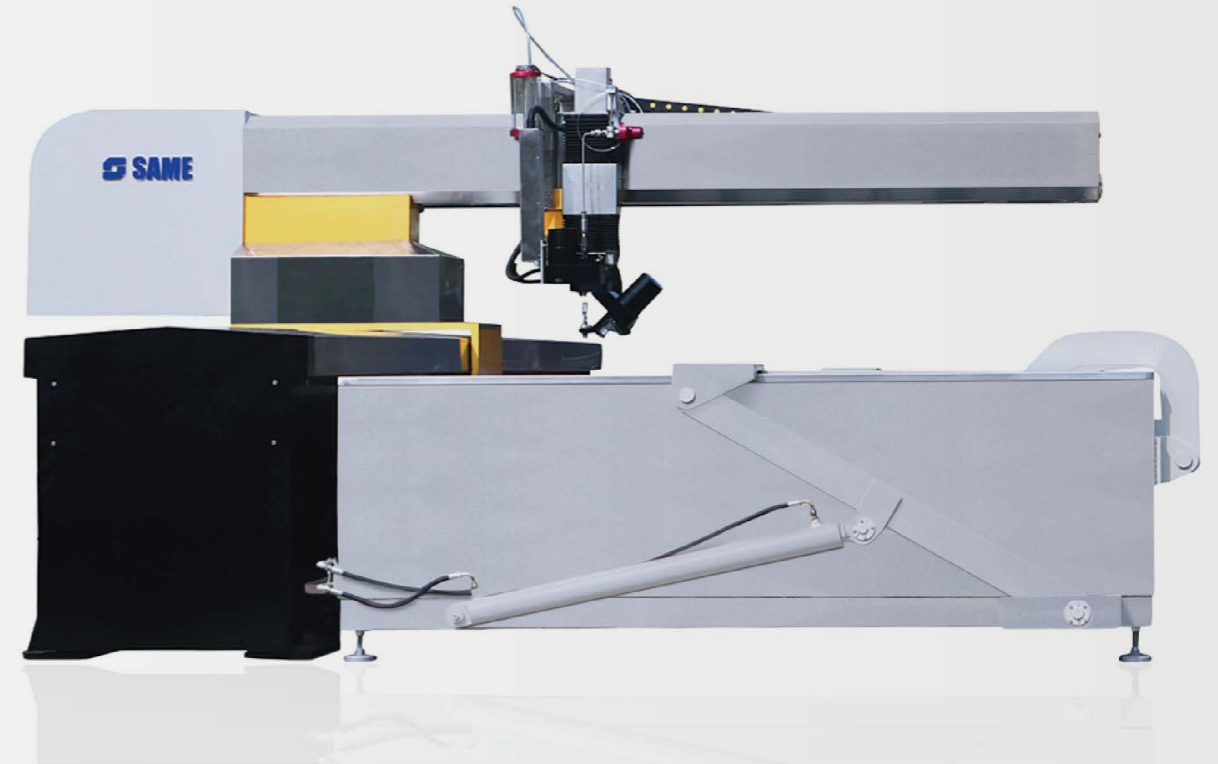

性能技术参数 / TECHNICAL PARAMETER

型号(Type)	2516	3020	4020
外形尺寸(mm)Dimension	3450*3200	3950*3800	4950*3800
最大切割范围(mm)Biggest Cutting Range	2500*1600	3000*2000	4000*2000
Z轴行程Travel of Z axis	150mm		
控制精度Control accuracy	± 0.01 mm		
切割精度Cutting accuracy	± 0.1 mm		
重复定位精度Re-positioning accuracy	± 0.025 mm/m		
机床空载最快移动速度Max. moving speed	18000mm/min		

特点描述：

- ◆ 高强度悬臂结构,可从三面上料
- ◆ 总线伺服系统,实现精准切割
- ◆ 自动润滑系统
- ◆ 水箱与运动结构分离,精度更高

ATTRIBUTE :

- ◆ High strength cantilever structure. load from three sides
- ◆ NC servo system for precise cutting
- ◆ Automatic lubrication system
- ◆ The water tank is separated from the cantilever higher precision

GANTRY TYPE CUTTING TABLE

WL系列龙门式切割平台



性能技术参数 / TECHNICAL PARAMETER

型号(Type)	2515	3020	4020	6030
外形尺寸(mm)Dimension	3400*2650	3900*3050	4900*3050	6950*4050
最大切割范围(mm)Biggest Cutting Range	2500*1500	3000*2000	4000*2000	6000*3000
Z轴行程Travel of Z axis	150mm			
控制精度Control accuracy	±0.01mm			
切割精度Cutting accuracy	±0.1mm			
重复定位精度Re-positioning accuracy	±0.025mm/m			
机床空载最快移动速度Max. moving speed	18000mm/min			

特点描述 :

- ◆ 首创多重防尘系统,有效阻隔水砂进入
- ◆ 总线伺服系统,实现精准切割
- ◆ 自动润滑系统

ATTRIBUTE :

- ◆ Innovative multiple dust prevention system, effectively blocking water and abrasive
- ◆ NC servo system for precise cutting
- ◆ Automatic lubrication system

CNC CONTROL SYSTEM

CNC控制系统

特点描述 :

- ◆ 系统支持DXF文件无需CAM软件,降低编程难度,节省成本;
- ◆ 支持同一图形上不同线段的角度及速度设置,实现不同坡口的线段连续切割;
- ◆ 采用激光测高,有效解决接触测量导致岩板弯曲不平的问题;
- ◆ 对图形中不同倾角的邻线段采取优化走刀策略,保证较好的切割效果。
- ◆ 支持拆单软件及CAD刀路,实现不同倾角切割;
- ◆ 自动识别内孔和外框,实现优化运动切割;
- ◆ 支持不同倾斜角不同刀补,保证加工精度一致性;
- ◆ 支持图层方设置工艺参数,提高加工效率。

ATTRIBUTE :

- ◆ System supports DXF files without CAM software, which reduces programming difficulty and saves costs;
- ◆ Support the angle and speed setting of different line segments on the same graph to realize continuous cutting of line segments with different grooves;
- ◆ Laser height measurement is used to effectively solve the problem of uneven rock slab bending caused by contact measurement;
- ◆ Adopt an optimized cutting strategy for adjacent line segments with different inclination angles in the graph to ensure a better cutting effect.
- ◆ Support splitting software and CAD toolpath to realize cutting at different inclination angles;
- ◆ Automatically recognize the inner hole and outer frame to realize optimized motion cutting;
- ◆ Support different inclination angle and different tool compensation to ensure the consistency of machining accuracy;
- ◆ Support layer side to set process parameters to improve processing efficiency.



性能技术参数 / TECHNICAL PARAMETER

外形尺寸(长*宽*高) Dimension (L*W*H)	600mm*550mm*1200mm
外形尺寸(mm)Dimension	200Kg
电源Power supply	380V 50HZ

AUTOMATIC ABRASIVE FEEDER

自动供砂系统

特点描述 :

- ◆ 自动供应切割磨料到切割刀头,缺磨料时可自动警报,结构简单、操作方便

ATTRIBUTE :

- ◆ Delivery abrasive to cutting head automatically, alerting automatically when there are lack of abrasive, it's simple structure easy operate and maintenance



性能技术参数 / TECHNICAL PARAMETER

外形尺寸(长*宽*高) Dimension (L*W*H)	600mm*550mm*1200mm
重量Weight	80Kg
电源Power supply	200Kg
最大供气压力Max. air pressure supply	0.2Mpa
控制电压Voltage	24V
总功率Power rate	30W

SWEDEN IGEMS SOFTWARE(OPTIONAL)

瑞典IGEMS软件 (选配)

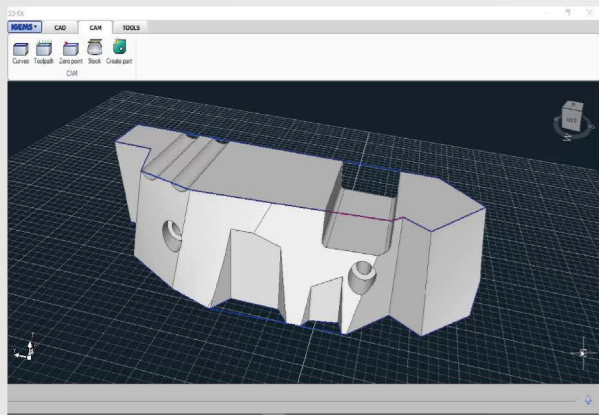

特点描述 :

- ◆ IGEMS软件可以便捷的导入CAD图形以及3D图形,支持DXF、DWJ、IGS等常用格式,对图形进行规划后可以快速的生成切割路径并进行切割;
- ◆ 可以直接扫描图形轮廓并生成图形,经过处理后可以非常方便的切割该图案;
- ◆ 瓷砖切割和嵌套功能在石材拼花具有非常实用的功能,可以非常方便的实现板料自动填充,并可以对各类板料进行排版规划切割;
- ◆ 可以快捷地对选中的图形进行全自动排版(单板料或多板料排版),并规划各个图形的排版数量;
- ◆ 实用的坡口切割功能,包括上坡口、下坡口、上下复合坡口等,软件还可使用共边切割、动态穿孔等水切割平台专用的特殊功能。

ATTRIBUTE :

- ◆ IGEMS software can easily import CAD graphics and 3D graphics, support COMMON formats such as DXF, DWJ, IGS, etc., and can quickly generate cutting path and carry out cutting after graph planning;
- ◆ It can scan the contour of the graph directly and generate the graph. After processing, it can cut the pattern very conveniently.
- ◆ Ceramic tile cutting and nesting functions have very practical functions in stone parquet, which can be very convenient to realize the automatic filling of sheet materials, and can be typesetting planning and cutting of all kinds of sheet materials;
- ◆ Can quickly select the graphic automatic typesetting (sheet or multi-sheet typesetting), and planning the number of graphic typesetting;
- ◆ Practical bevel cutting functions, including ramp, ramp, upper and lower compound bevel, etc., the software can also use common edge cutting, dynamic perforation and other special functions of water cutting platform.

GERMANY BECKHOFF CONTROL SYSTEM(OPTIONAL)

德国倍福控制系统 (选配)

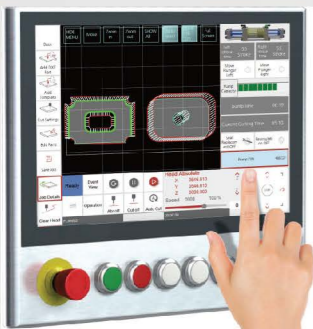

ATTRIBUTE :

- ◆ Contronest USA CNC controller runs on German made high performance Beckhoff® Embedded industrial PC Thanks to EtherCAT® technology, less wiring and a lower maintenance are needed;
- ◆ Combining unmatched advanced 5 axes software compensation and fine laser mapping can achieve higher accurate bevel cutting and sharper, cleaner edges;
- ◆ Embedded CAM Program including but not limited to built-in templates, DXF import with DXF-checker, automatic tool compensation, lead in/out and advanced beveling options;
- ◆ Comprehensive material database determines the optimal pressure and abrasive rate for cutting. Also, it will determine the recommended variant cutting speed along the path to Save Power/abrasive and increase efficiency;
- ◆ Integrated operation interface with PLC functions runs under the same controller to control the pump, the abrasive rate, and set the cutting pressure. It also monitors the alarms and all the pump's and machine's events.

特点描述 :

- ◆ 美国Contronest CNC控制器运行基于德国高性能倍福®嵌入式工业PC,得益于EtherCAT®技术,接线更少,维护成本更低;
- ◆ 结合无与伦比的高级5轴软件补偿和精细的激光测绘可以实现更高精度的斜角切割;
- ◆ 嵌入式CAM程序,包括但不限于内置模板,带有DXF检查器的DXF导入,自动刀补,自动导入/导出的引刀线和高级倒角选项;
- ◆ 全面的材料数据库帮助选定最佳切割时所需的压力和磨料速率。此外,它会根据系统推荐的切割速度不断的调整,以达到节省电量/磨料以及增加效率;
- ◆ 具有PLC功能的集成操作界面运行在同一控制器下控制高压泵、磨料速度以及设置切割压力,同时,它检测警报以及所有关于泵和机床的运行记录。

SLUDGE REMOVAL SYSTEM(OPTIONAL)

自动清淤系统 (选配)



OPTIONAL (选配)

特点描述 :

- ◆ 利用压缩空气驱动气动隔膜泵,及时吸除水箱中的水刀砂料,减少水箱内的淤泥沉积,提高工作效率

ATTRIBUTE :

- ◆ Use compressed air to drive a pneumatic diaphragm pump, help to remove sludge from the water tank while working save time and labor.

性能技术参数 / TECHNICAL PARAMETER

设备直径Equipment diameter	1m
容量Capacity	1000L
重量 Weight	650Kg
高度Height	2.3m
隔膜泵流量Diaphragm pump flow	8m³/h
排沙量 Sand removal	0.65m³/h

HYDRAULIC LOADING PLATFORM(OPTIONAL)

液压落地上料翻转台(只适配悬臂4020机型) (选配)

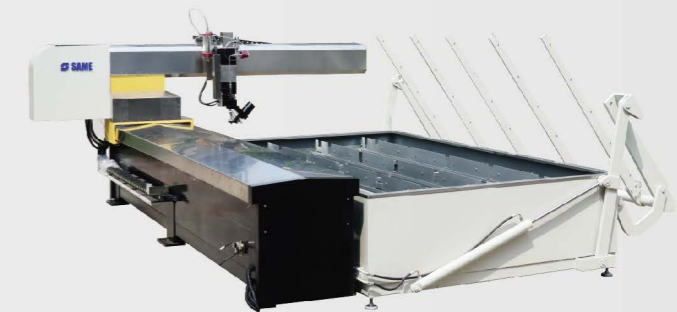

OPTIONAL (选配)

特点描述 :

- ◆ 落地上料翻转台可以解决大批量生产加工时频繁上下料的问题,提高工作效率,对需要加工大型工件的客户提便利。

ATTRIBUTE :

- ◆ The hydraulic platform helps users loading and unloading material sheets, improve production effect, especially helpful for users who cutting large size of material sheets

ALLFI ABRASIVE DELIVERY SYSTEM(OPTIONAL)

Allfi磨料输送罐 (选配)



OPTIONAL (选配)

特点描述 :

- ◆ Allfi磨料输送罐源于瑞士allfi水切割配件公司。可以数字化精确的调整进砂量(它的持续配量范围从0-36kg/小时,或者0-600克/分钟)系统可以由外置的模拟信号或者电位器控制。

ATTRIBUTE :

- ◆ All abrasive delivery system can be adjusted very precisely(continuous dosing in a range from 0-36 KG/hour or 0-600g/min.) The system are controlled either by external analogue signal or a potentiometer

AC5 AXIS CUTTING SYSTEM(OPTIONAL) AC五轴切割系统 (选配)

特点描述 :

- ◆ 实现0°~45°范围内任意角度切割
- ◆ 岩板加工必备
- ◆ 解决传统水切割斜度问题,轻松实现2D/3D切割

ATTRIBUTE :

- ◆ AC5 axis cutting head system can offer 0°~45° bevel cutting
- ◆ Equipped with professional waterjet programming software
- ◆ Solve the bevel cutting of traditional waterjet,achieve 2D/3D cutting easily



OPTIONAL (选配)

性能技术参数 / TECHNICAL PARAMETER

A轴旋转角度A axis	±67°
C轴旋转角度C axis	±360°
切割工件角度Bevel cutting	±45°

OAB5 AXIS CUTTING SYSTEM(OPTIONAL) OAB五轴切割系统 (选配)



特点描述 :

- ◆ 相对传统ab五轴,效率提升10%以上
- ◆ 制作完美拼花必备,实现完美尖角,省去打磨环节,有效节省人工

OPTIONAL (选配)

ATTRIBUTE :

- ◆ OAB5 axis cutting head system was special designed for users of marble inlay work
- ◆ Equipped with professional waterjet programming software

性能技术参数 / TECHNICAL PARAMETER

A轴旋转角度A axis	±10°
C轴旋转角度C axis	±10°
切割工件角度Bevel cutting	±5°

PARTS OF AWJ CUTTING HEAD AWJ切割刀头配件图



PARTS OF HJ400 DIRECT DRIVE PUMP HJ400直驱式超高压泵配件图



PARTS OF 50HE/50HC HYDRAULIC DRIVE PUMP 50HE/50HC液压式超高压泵配件图



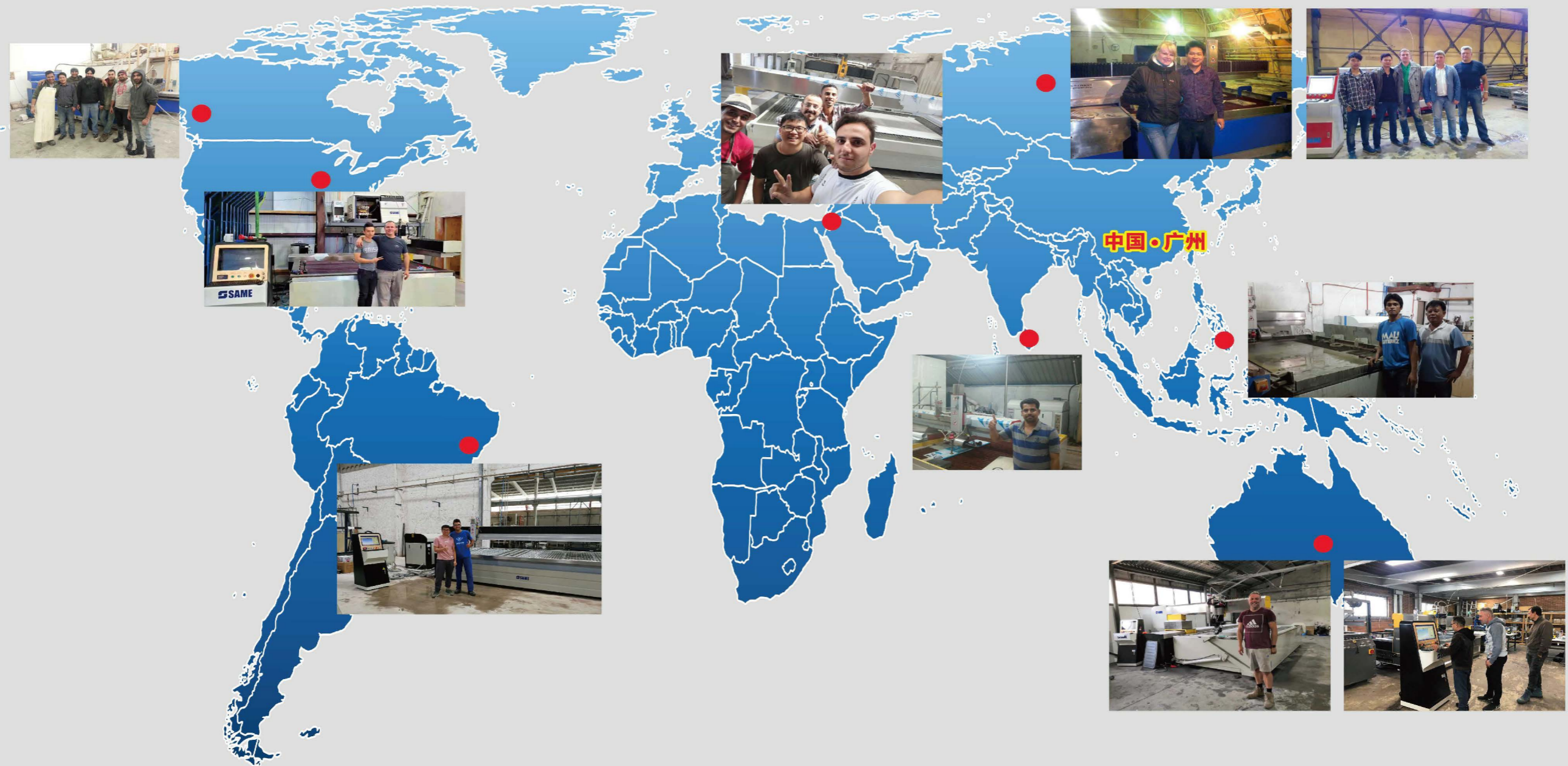

SALES NETWORK IN MORE THAN 60 COUNTRIES

销售网络遍布60多个国家



对所有已经购买华臻产品的客户,华臻将提供如下服务:

1. 为用户培训设备操作人员,能使得客户在最短的时间内了解和掌握华臻水刀的工作原理、操作方法、维修方法,保证客户在最短的时间内熟练运转机器.
2. 提供设备的安装调试,12个月(或2500小时)的质保期(以先到为准).
3. 终生负责维修,保证零配件长期供应,解决客户后顾之忧.
4. 服务网络跟踪电话回访、客户走访,以多种方式及时解决客户的实际问题.
5. 对新产品和新技术,享受特价升级.

AFTER-SALE SERVICE:

1. Training personnel for operation and maintenance of equipment, make sure customers know the principle skills of operate and maintenance SAME waterjet.
2. Providing the equipment installation and commissioning, 12 months warranty period, except spare parts.
3. Lifetime maintenance, to ensure long-term spare parts supply, to solve customers problems.
4. After-sale follow up, telephone support and customer visit, in a variety of ways to solve problems timely.
5. Upgrading new products and new technologies with discount price.